

A. D. WAYMOTH.
Wood-Turning Lathe.

No. 213,718.

Patented Mar. 25, 1879.

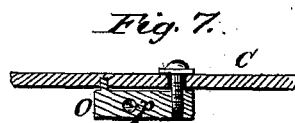
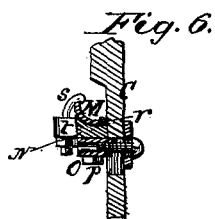
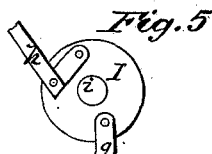
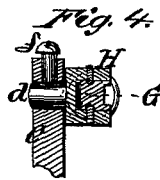
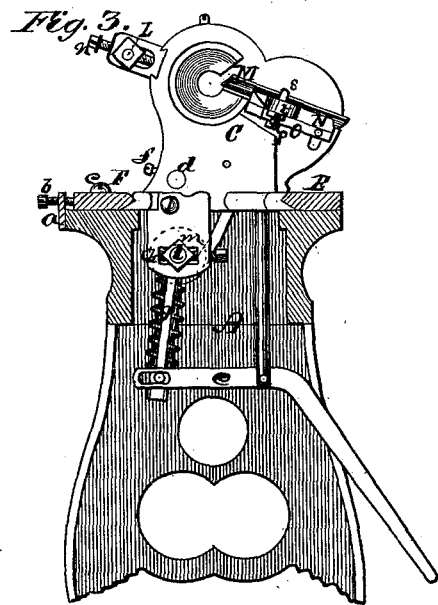
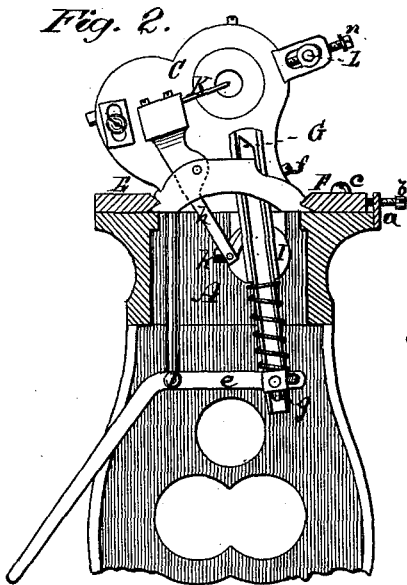
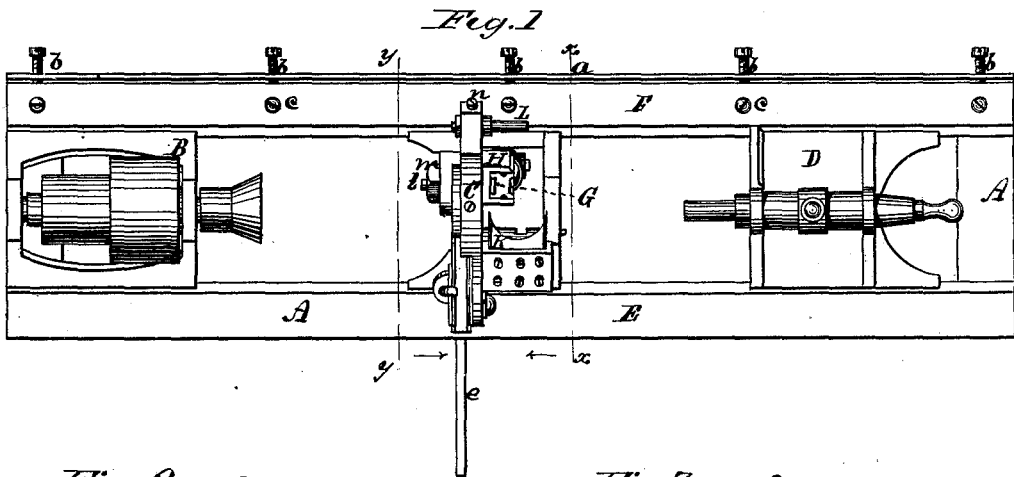

Witnesses
Fred G. Dietrich
Edgar G. Malford

Inventor
Augustine D. Waymorth,
By J. S. Brown,
his attorney.

UNITED STATES PATENT OFFICE.

AUGUSTINE D. WAYMOTH, OF FITCHBURG, MASSACHUSETTS.

IMPROVEMENT IN WOOD-TURNING LATHES.

Specification forming part of Letters Patent No. **213,718**, dated March 25, 1879; application filed June 29, 1878.

To all whom it may concern:

Be it known that I, AUGUSTINE D. WAYMOTH, of Fitchburg, in the county of Worcester and State of Massachusetts, have invented Improvements in Wood-Turning Lathes; and I do hereby declare that the following is a full and exact description thereof, reference being had to the accompanying drawings, making part of this specification—

Figure 1 being a top view of a wood-turning lathe constructed with my improvements; Fig. 2, a transverse vertical section thereof in a plane indicated by the line *x x*, Fig. 1; Fig. 3, a transverse vertical section of the same in a plane indicated by the line *y y*, Fig. 1; Figs. 4, 5, 6, and 7, partial and detached views of parts of the lathe.

Like letters designate corresponding parts in all of the figures.

The several improvements herein described are especially upon the wood-turning lathe patented by me June 6, 1876, No. 178,255, but are applicable to other lathes operating on similar principles.

In the drawings, A represents the frame of the lathe; B, the head-stock; C D, respectively, the tool and tail carriages, which slide on ways E F, one fixed and the other movable.

My first improvement consists in an improved means of adjusting the movable way, F, on which the carriages C D slide, as follows: The bed on which the way rests has a rib or upwardly-projecting flange, *a*, outside of the way, into which flange or flanges set-screws *b b* are inserted for adjusting the way F accurately to the sliding carriages, so that they will slide closely and accurately, and yet with sufficient freedom, between the ways—a thing very difficult or impracticable to effect by means heretofore in use. The way F is secured in position by fastening-screws *c c*, passing down through cross-slots in the way into the bed beneath.

My next improvement consists in the mode of mounting the cutting-off tool G, which is to be applied when the articles to be turned are automatically cut from the stick at the completion of the turning, so as to have an adjustment in or out to accurately reach the center line of the stick being worked, and also

lengthwise thereof to sever the articles at the exact point required. For this purpose the case or holder H (shown separately in Fig. 4) is provided with a stud or pin, *d*, projecting from it at right angles, to enter a hole in the tool-carriage C, wherein it is held by a set-screw, *f*, to retain the holder in the desired angular position for the in-and-out adjustment, and more or less inserted in its hole or bearing to produce the longitudinal adjustment. Thus the tool is exactly and quickly adjusted to any work, and the shaping and adapting of tools to each varied purpose, so slow and troublesome heretofore, is obviated.

The next feature of improvement consists in the arrangement of the crank or eccentric wheel I, to which are pivoted the connecting-rods *g h*, by which the movements of the cutting-off and forming tools are controlled, so as to be adjustable in or out, to give more or less cut to the forming-tool K, as required for different work or to adapt the tool to any work. The said connecting-rods *g h* are so pivoted to or connected with the wheel or disk I, in relation to each other and to the movement of the said wheel or disk, that by a partial revolution given to the latter the knife K, controlled by the rod *h*, is withdrawn from the work simultaneously with the forward movement of the knife G, controlled by the rod *g*, which, at its lower end, is connected with a lever, *e*, whereby movement is communicated to the wheel or disk I, substantially as indicated in the drawings. This adjustment is effected by the insertion of the pivot or stud *i*, Fig. 5, on which the wheel turns or vibrates, in a cross slot or hole, *k*, in the tool-carriage, to be adjusted transversely therein by a set-screw, *l*, and held in place by a fastening-nut, *m*, or by equivalent means. This improvement obviates many inconveniences and imperfections heretofore incident to this part of the lathe.

Another improvement consists in a stud or pin, L, mounted in the back side of the tool-carriage C, opposite to the forming-tool K, upon which stud is supported, by a pivot-bearing or otherwise, a finishing-knife, (not shown in the drawings,) to be moved to the work either by hand or automatically by the cutting-off tool G, or otherwise. This stud is arranged in a position parallel with the longi-

tudinal axis of the lathe, and is adjustable in a slot of the carriage, in or out, toward or from the center of the work, by a set-screw, *n*, or its equivalent.

The next feature of improvement consists in mounting the roughing-knife M on a bed, N, which is adjustable laterally on a stationary ledge or support, O, Fig. 6, of the tool-carriage by a set-screw or set-screws, *p*, so that the inner or cutting end of the knife may be adjusted laterally or in angular position lengthwise of the stick on which it works and give its edge more or less "rake."

A further improvement consists in securing the knife M upon the bed N in an open socket in the upper side of the said bed without any hole in the knife or bed in the following manner: One edge of the knife fits under a lip or projecting edge, *r*, of the bed; and the knife is held by a hook-bolt, *s*, hooking over its other edge, and extending down through a boss or lug, *t*, of the ledge *o*, to be drawn and held down by a nut underneath, as shown in Fig. 6. The more tightly this outer upper edge of the knife is thus drawn down the more tightly its other edge is held under the lip *r*.

This construction is cheaper than others, allows the knife to be adjusted along till a great part of it is worn away, and leaves the knife open and free for the ready escape of the chips and shavings. There is also a saving of time thereby in removing and replacing the knife.

This improvement is applicable to all lathes in which a ring or bearing supports the stick to be turned.

What I claim as my invention, and desire to secure by Letters Patent, is—

1. The lathe-bed provided with a project-

ing rib or flange, *a*, and set-screws *b b*, in combination with the movable way F, substantially as and for the purpose herein specified.

2. The cutting-off tool G, made adjustable by means of its holder H, provided with a stud or pin, *d*, inserted in the tool-carriage C, and held adjustably therein by a set-screw, *f*, substantially as and for the purpose herein specified.

3. The crank-wheel I, mounted on a laterally-adjustable pivot, *i*, in combination with the cutting-off tool G, forming-tool K, actuating-lever *e*, and their respective connecting-rods *g h*, substantially as and for the purpose herein specified.

4. In combination with the tool-carriage C, a stationary stud or pin, L, on which to mount a removable finishing-knife, the said stud or pin being arranged in a position parallel with the longitudinal axis of the lathe, and adjustable toward and from the said axis by a set-screw, *n*, and slot in the carriage, or their equivalent, substantially as herein specified.

5. The bed N, on which the roughing-knife M is mounted, made adjustable upon a support, O, by means of a pivot-screw, *p*, and tightening-nut, substantially as and for the purpose herein specified.

6. The device for securing the roughing-knife M on its bed N, consisting of the holding-lip *r* on the said bed, and a hook-bolt, *s*, or its equivalent, arranged in combination with the said roughing-knife, substantially as and for the purpose herein specified.

AUGUSTINE D. WAYMOTH.

Witnesses:

CHAS. S. HAYDEN,
F. A. WOOD.